

PLAN VIEW

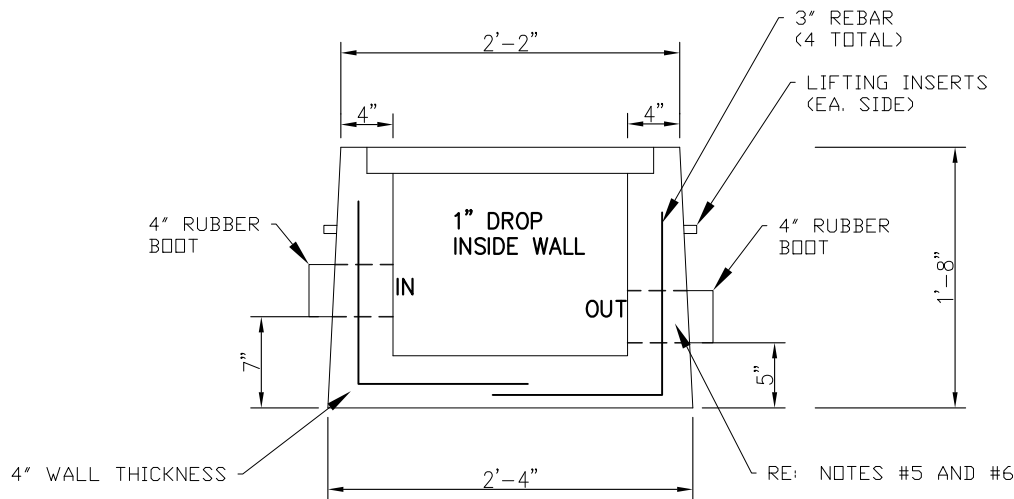

SIDE VIEW

NOTES:

1. CONCRETE THICKNESS SHALL BE AS SHOWN.
2. CONCRETE STRENGTH =6000 PSI. THE WATER-CEMENT RATIO SHALL NOT EXCEED 0.45.
3. REINFORCING SHALL BE GRADE 40 #3 OR #4 BARS AS SHOWN.
4. REINFORCING SHALL BE PLACED AT THE CENTER OF SLABS AND WALLS.
5. THE DIAMETER OF THE INLET AND OUTLET CAN VARY FROM 2" TO 4".
6. THE DROP IN THE WELL FROM INLET TO OUTLET CAN BE ADJUSTED PER ORDER.

PROJECT: 18" SAMPLING PORT/WELL

ISSUE DATE:

10-23-2017

**Hausner's Limited**

P.O. Box 1307 Durant, OK 74702-1307

Phone: 580-924-6988 Fax: 580-924-6742

SHEET NUMBER:

**S-01**

*Coombs Engineering, P.C.*

STRUCTURAL ENGINEERS

1701 N. Greenville Ave, Suite 815

Richardson, Texas 75081 214-287-4696

Reg # F-13205

